

adStar-L



advanced digital chips inc.

(주)에이디칩스

431-060
경기도 안양시 동안구 관양동 810 금강센터빌 A동22층
http://www.adc.co.kr

adStar-L STK Designed by .taigeun.kim
taigeun@adc.co.kr

Size	Page Subtitle	Ver.
A3	adStar-L	1.1

Date : Thursday, March 03, 2016 Page 1 of 8

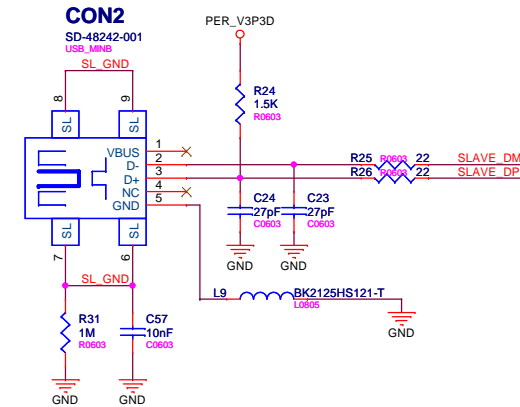
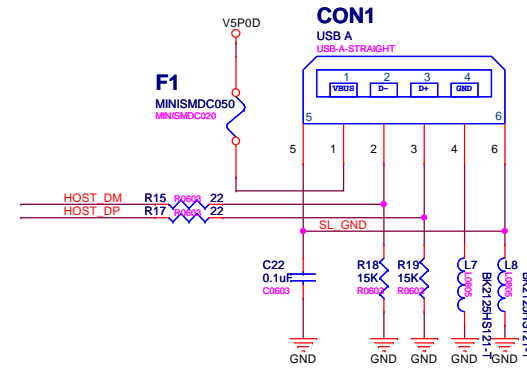
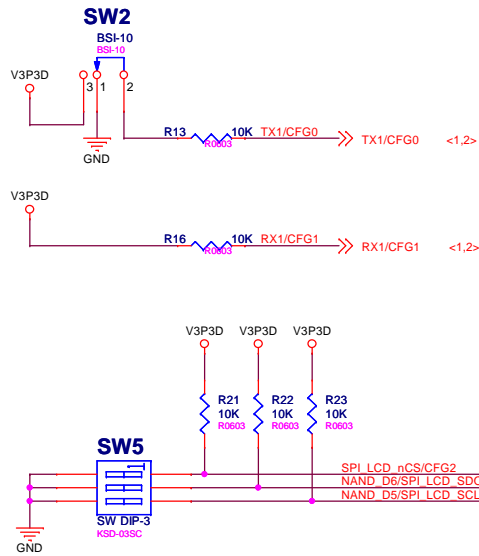

CFG[0]	LOW : DEBUGGER MODE HIGH : NORMAL BOOTING MODE
CFG[1]	LOW : Not Used HIGH : Default SWD
CFG[0] : HIGH	SPI Flash Boot CFG[4:2] : 111
	NANDFlash Boot CFG[4:2] : 000 (Small 3Cycle) 001 (Small 4Cycle) 010 (Large 4Cycle) 011 (Large 5Cycle) 100 (MLC 4bit ECC) 101 (MLC 24bit ECC)

SW3	SW4	MODE(Software)
LOW	LOW	USER DEFINE
LOW	HIGH	USB COMMUNICATION
HIGH	LOW	MASS STORAGE
HIGH	HIGH	EXECUTE

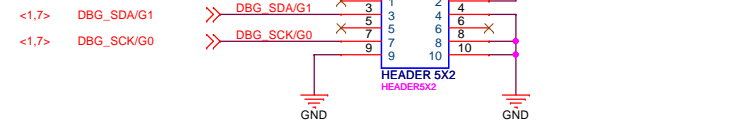
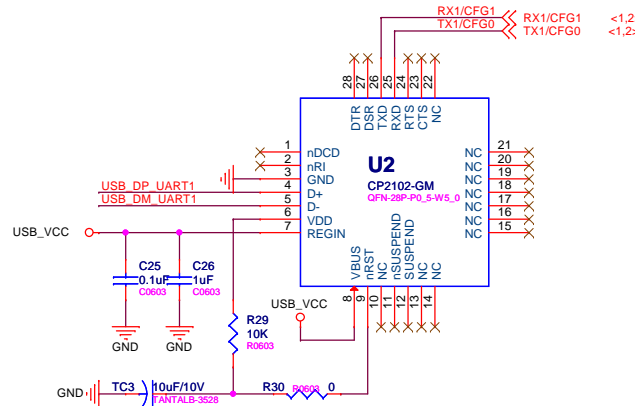
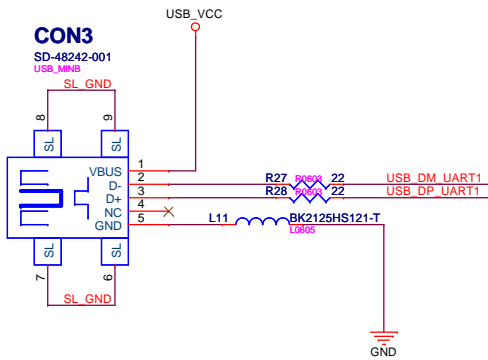
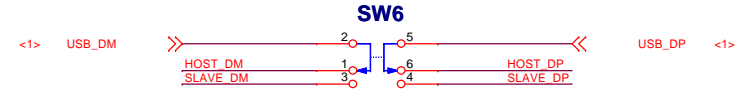

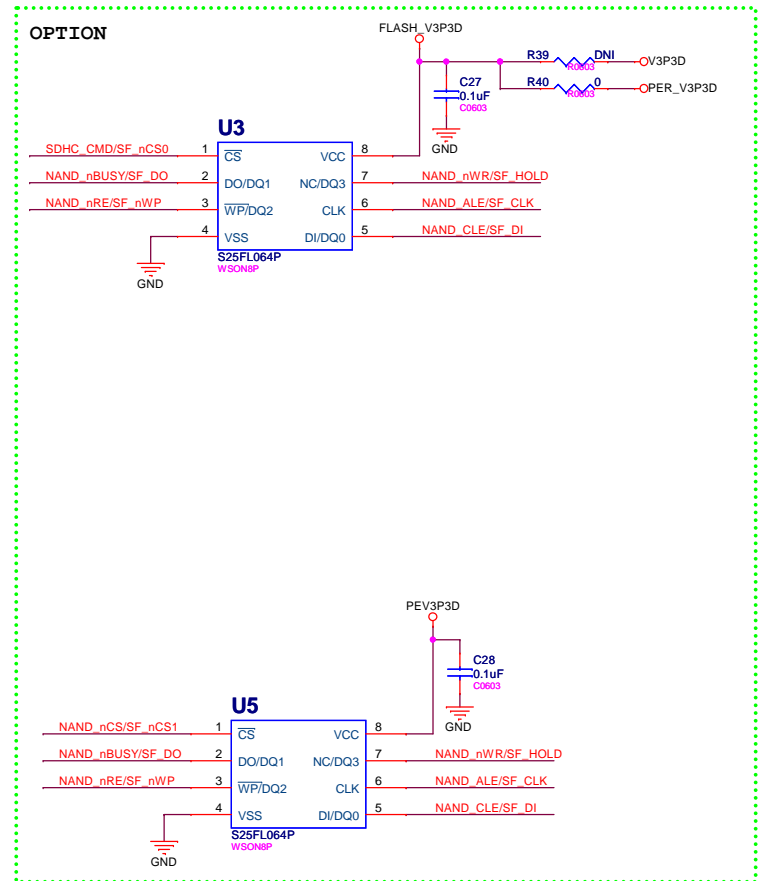
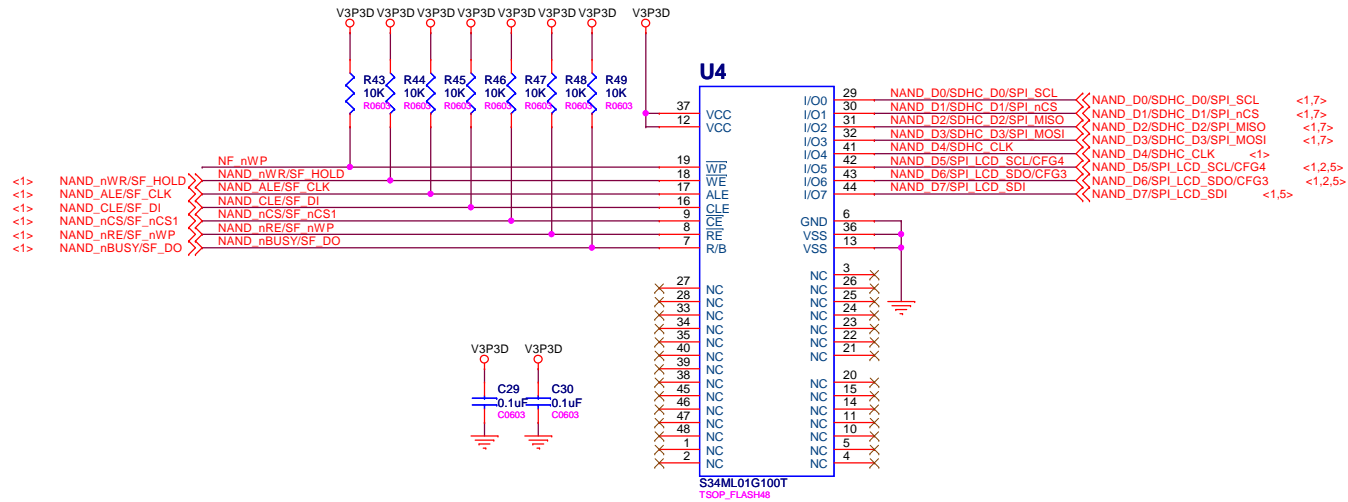
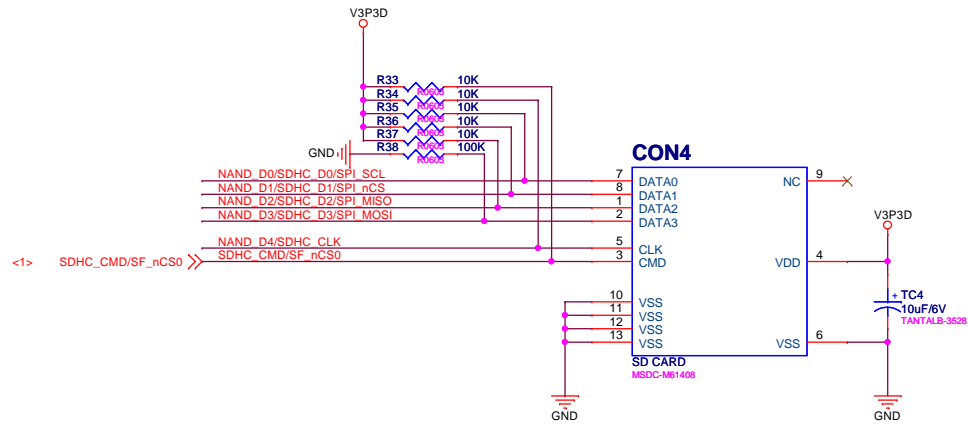

 advanced digital chips inc.	(주)에이디칩스 431-060 경기도 안양시 동안구 권양동 810 금강랜타리움 A동22층 http://www.adc.co.kr
	Title adStar-L STK Size Page Subtitle A3 CFG & SWD & USB Date : Thursday, March 03, 2016

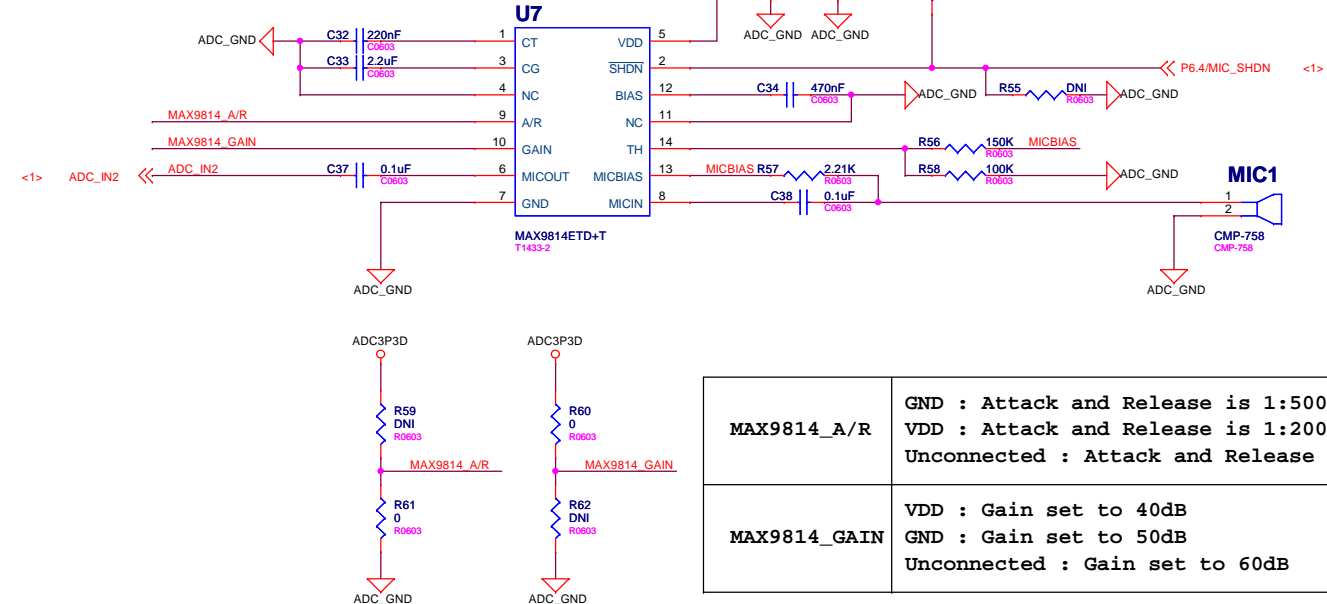
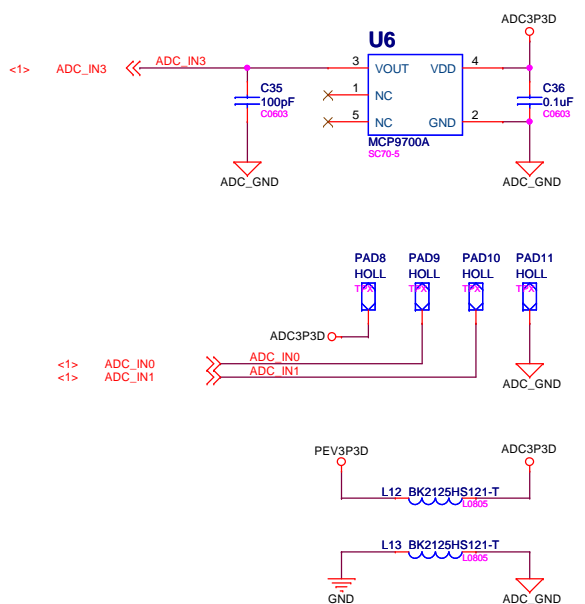

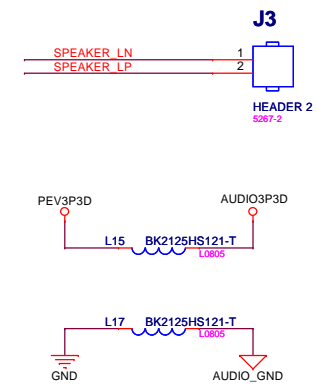
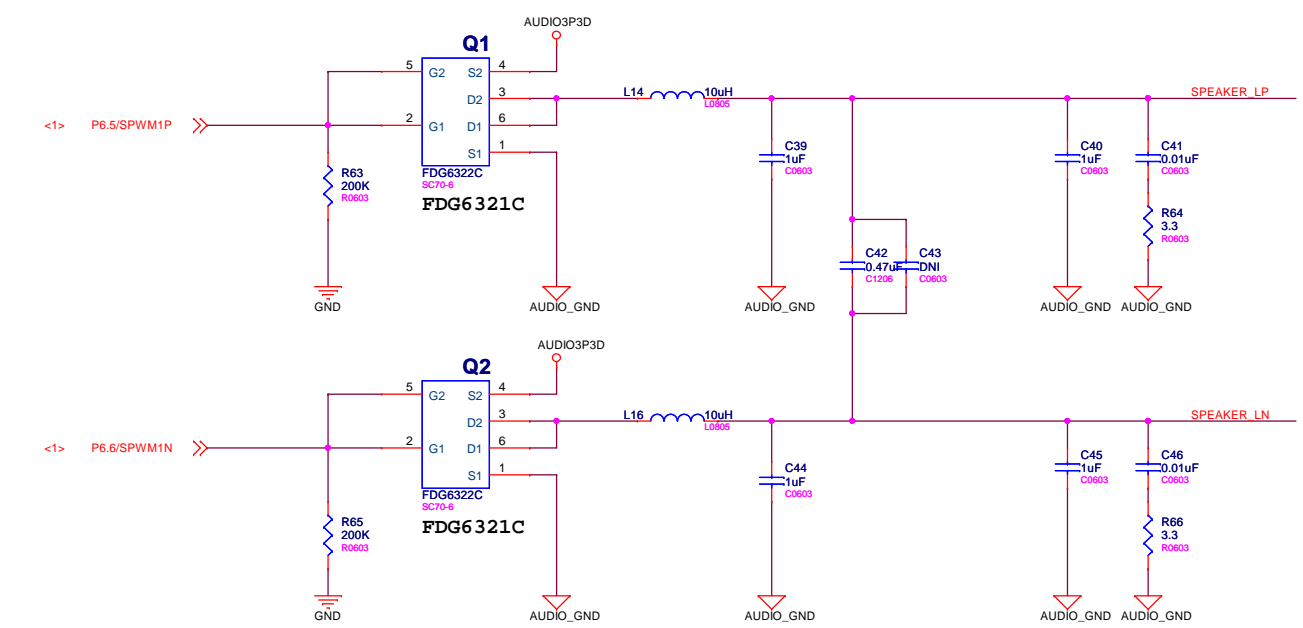

MAX9814_A/R	GND : Attack and Release is 1:500 VDD : Attack and Release is 1:2000 Unconnected : Attack and Release is 1:4000
MAX9814_GAIN	VDD : Gain set to 40dB GND : Gain set to 50dB Unconnected : Gain set to 60dB





advanced digital chips inc.
http://www.adc.co.kr

(주)에이디칩스

431-060
경기도 안양시 동안구 관양동 810 금강벤처리움 A동22층
http://www.adc.co.kr

Title		adStar-L STK		Designed by taigeun.kim taigeun@adc.co.kr	
Size	Page Subtitle			Ver.	
A3	MIC & AUDIO PWM			1.1	
Date	Monday, January 25, 2016	Page	4	of	8

4.3" RGB LCD 5:6:5 INTERFACE

1.77" SPI LCD CONNECTOR

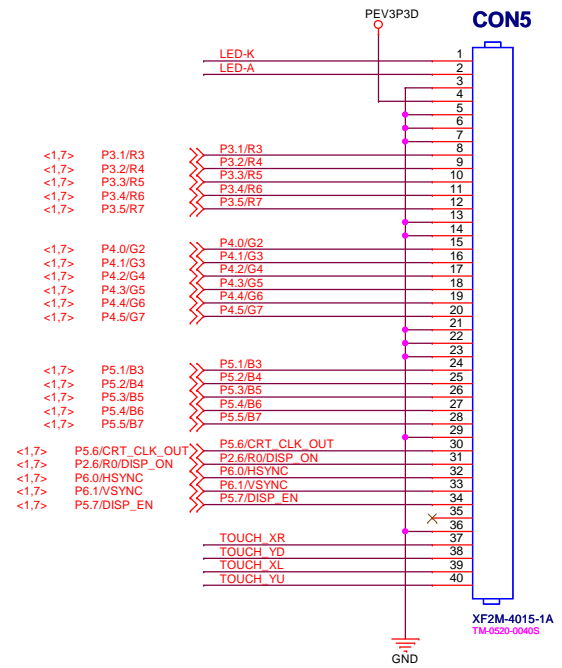

TM0520-0040 (상하접점)

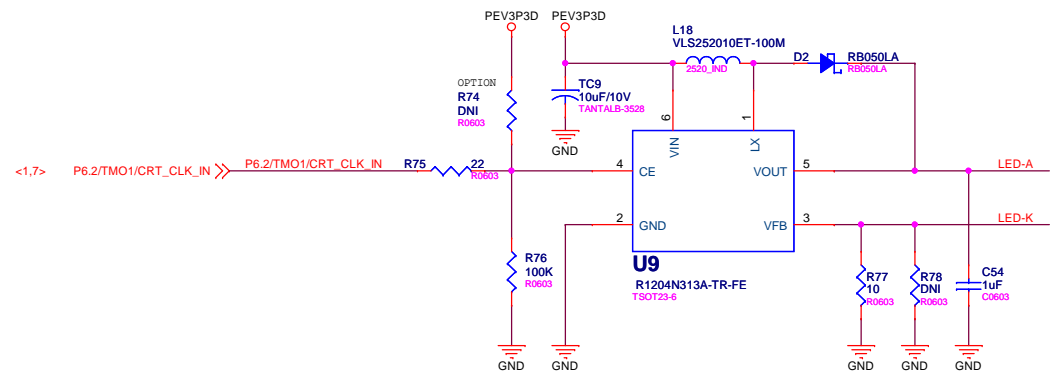
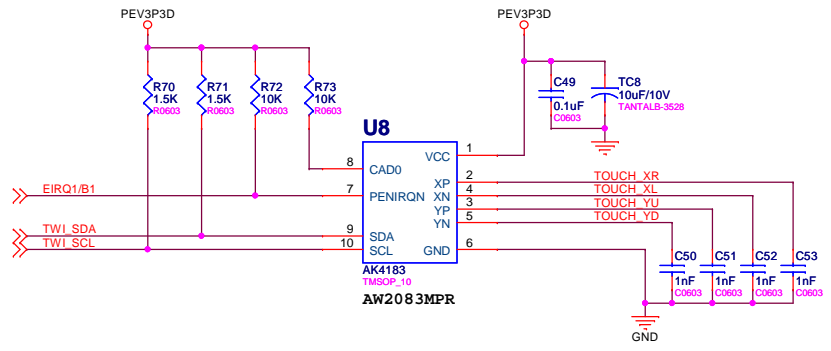
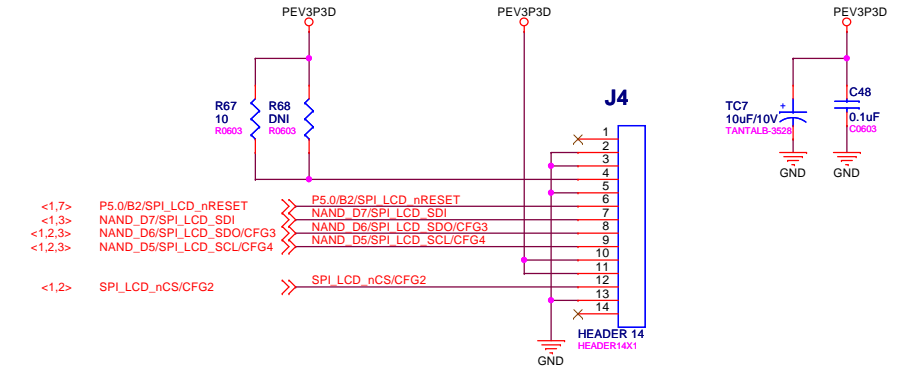
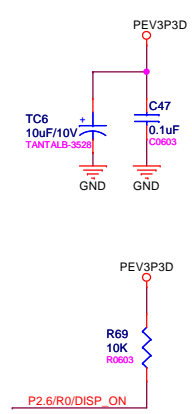



advanced digital chips inc.
http://www.adc.co.kr

(주)에이디칩스

431-060
경기도 안양시 동안구 관양동 810 금강랜타리움 A동22층
http://www.adc.co.kr

Title		adStar-L STK		Designed by .taigeun.Kim taigeun@adc.co.kr	
Size	Page Subtitle			Ver.	
A3	4.3 INCH & SPI TFT-LCD			1.1	
Date	Friday, May 13, 2016	Page	5 of 8		

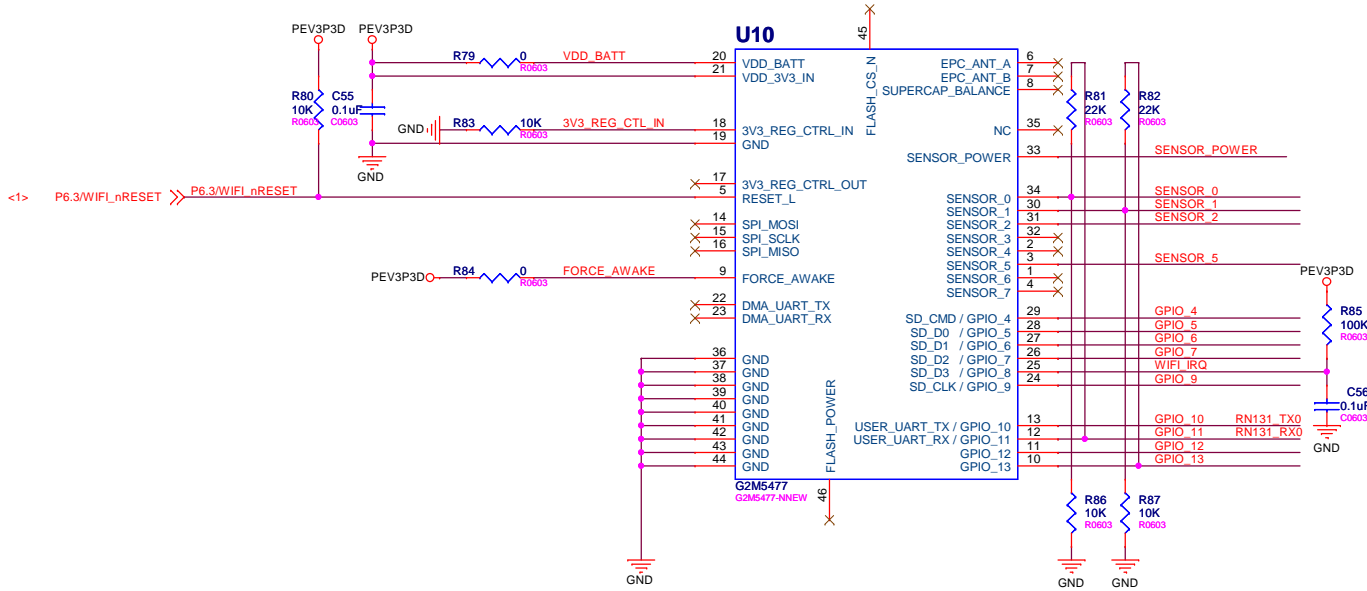

Condition	Red LED	Yellow LED	Green LED
ON solid			Connected over TCP
Fast blink	Not Associated	Rx/Tx data transfer	No IP address
slow blink			IP address OK
OFF	Associated		

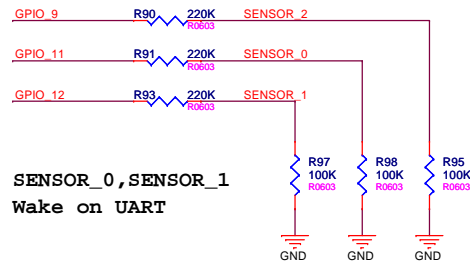
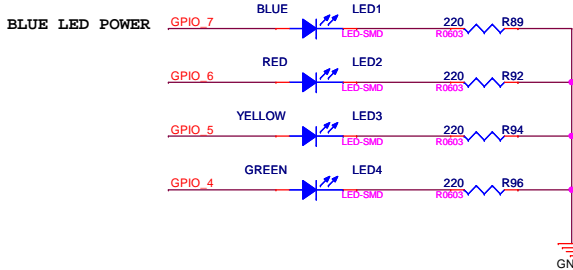
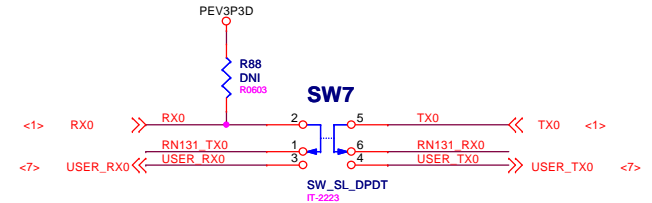

SENSOR_0, SENSOR_1
Wake on UART

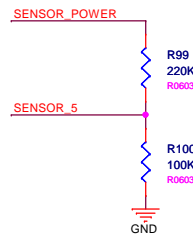

 advanced digital chips inc.	(주)에이디칩스	
	431-060 경기도 안양시 동안구 관양동 810 금강랜타리움 A동22층 http://www.adc.co.kr	
Title		
adStar-L STK		Designed by .taigeun.Kim taigeun@adc.co.kr
Size	Page Subtitle	Ver.
A3	Wi-fi	1.1
Date : Monday, January 25, 2016		Page 6 of 8

