

## WiFly GSX 802.11 b/g Wireless LAN Module

### Features

- FCC / CE/ IC certified 2.4GHz IEEE 802.11b/g transceiver
- Small form factor: 1050 x 700 x 130 mil
- Configurable transmit power: 0dBm to 10 dBm
- RF pad connector for antennas
- Certified antennas: Chip antenna, 4" Dipole, PCB trace and wire antenna
- Ultra-low power - 4uA sleep, 38mA Rx, 120 mA Tx at 0dBm
- High throughput - 921Kbps TX, 500Kbps RX data rate with TCP/IP and WPA2 over UART, upto 2Mbps over SPI slave
- 8 Mbit flash memory and 128 KB RAM
- 10 general purpose digital I/O
- 8 analog sensor interfaces
- Real-time clock for wakeup and time stamping
- Accepts 3.3V regulated power supply or 3V battery
- Supports Adhoc and infrastructure networks
- On board complete TCP/IP networking stack
- Environmentally friendly- RoHS compliant.

### Applications

- Remote Monitoring
- Industrial sensors and controls
- Telemetry
- Home Automation



### Description

The RN-171 module is a standalone complete TCP/IP wireless networking module. Due to its small form factor and extremely low power consumption, the RN-171 is perfect for mobile wireless applications such as asset monitoring, sensors and portable battery operated devices. It incorporates a 2.4GHz radio, 32-bit SPARC processor, TCP/IP stack, real-time clock, crypto accelerator, power management and analog sensor interfaces. This module is preloaded with firmware to simplify integration and minimizes development of your application. In the simplest configuration the hardware only requires four connections (PWR, TX, RX and GND) to create a wireless data connection. Additionally, the analog sensor inputs can be used to interface a variety of sensors such as temperature, audio, motion and acceleration. The ability to go into deep sleep mode and automatically scan and associate to an AP when awake makes the RN-171 suitable for roaming applications. The RN-171 also includes a built in HTML client to automatically post serial uart data or sensor data to a web server.

### Block Diagram

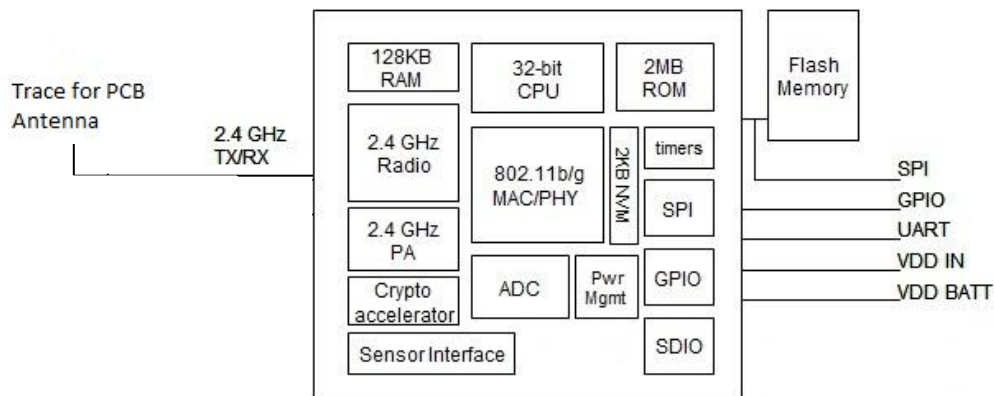

## Overview

- Host Data Rate up to 921 Kbps TX, 500 Kbps RX for UART, up to 2Mbps over SPI slave
- Intelligent, built-in power management with programmable wakeup
- Real time clock for time stamping, auto-sleep and auto-wakeup
- Configuration using simple ASCII commands
- Software controlled transmit power (0dBm to 10dBm) for ultra low power applications
- Memory 128 KB RAM, 2MB ROM, 2 KB battery-backed memory, 8 Mbit Flash.
- Secure WiFi authentication WEP-128, WPA-PSK (TKIP), WPA2-PSK (AES)
- Built in networking applications DHCP, UDP, DNS, ARP, ICMP, TCP, HTML client
- 802.11 power save and roaming functions
- Castellated pads for reliable soldering

## Environmental Conditions

Parameter	RN-171
Temperature Range (Operating)	-40 °C ~ +85 °C
Temperature Range (Storage)	-40 °C ~ +85 °C
Relative Humidity (Operating)	≤90%
Relative Humidity (Storage)	≤90%

## Electrical Characteristics (Provisional)

Supply Voltage	Min	Typ.	Max.	Unit
Supply Voltage (VBATT option)	3.0	3.3	3.7	VDC
<b>Digital Input</b>				
Input logic HIGH VIH	2.3V			VDC
Input logic LOW VIL			1.0V	VDC
<b>Digital Output drive</b>				
PIO 4,5,6,7,8		24		mA
PIO 9,10,11,12,13		8		mA
<b>Power consumption</b>				
Sleep		4		uA
Standby (doze)	-	15	-	mA
Connected (idle, RX)		40		mA
Connected (TX)*	0dBm	120		mA
	12dBm	190		mA

\*The transmit power can be controlled via firmware

## Analog Sensor Inputs

Parameter	Value
Sense 0,1,2,3 wakeup detect threshold	500mV
AD sense 0-7 measurement range	0-400mV ( <b>Do not exceed 1.2V DC</b> )
Resolution	14 bits = 12uV
Accuracy	5% un-calibrated, .01% calibrated
Minimum conversion time	35us (5kHz over Wi-Fi)
Sensor Power (pin 33) output resistance 3.3V	10 ohms, max current = 50mA

**Radio Characteristics**

Parameter	Specifications
Frequency	2402 ~ 2480MHz
Modulation	802.11b compatibility : DSSS(CCK-11, CCK-5.5, DQPSK-2, DBPSK-1) 802.11g : OFDM (default)
Channel intervals	5MHz
Channels	1 - 14
Transmission rate (over the air)	1 – 11Mbps for 802.11b / 6 – 54Mbps for 802.11g
Receive sensitivity	-83dBm typ.
Output level (Class1)	-2dBm to +12dBm (configurable via software)

**Transmit Power**

Output Power	802.11 b (2Mbps) Current in mA*	802.11 g (24Mbps) Current in mA*
0	120	135
2	130	150
4	170	190
6	175	200
8	180	210
10	185	225
12	190	240

\* Measured at 3.3VDC VCC. The power consumption is the average power, active during actual power consumption

## Typical Application Circuit

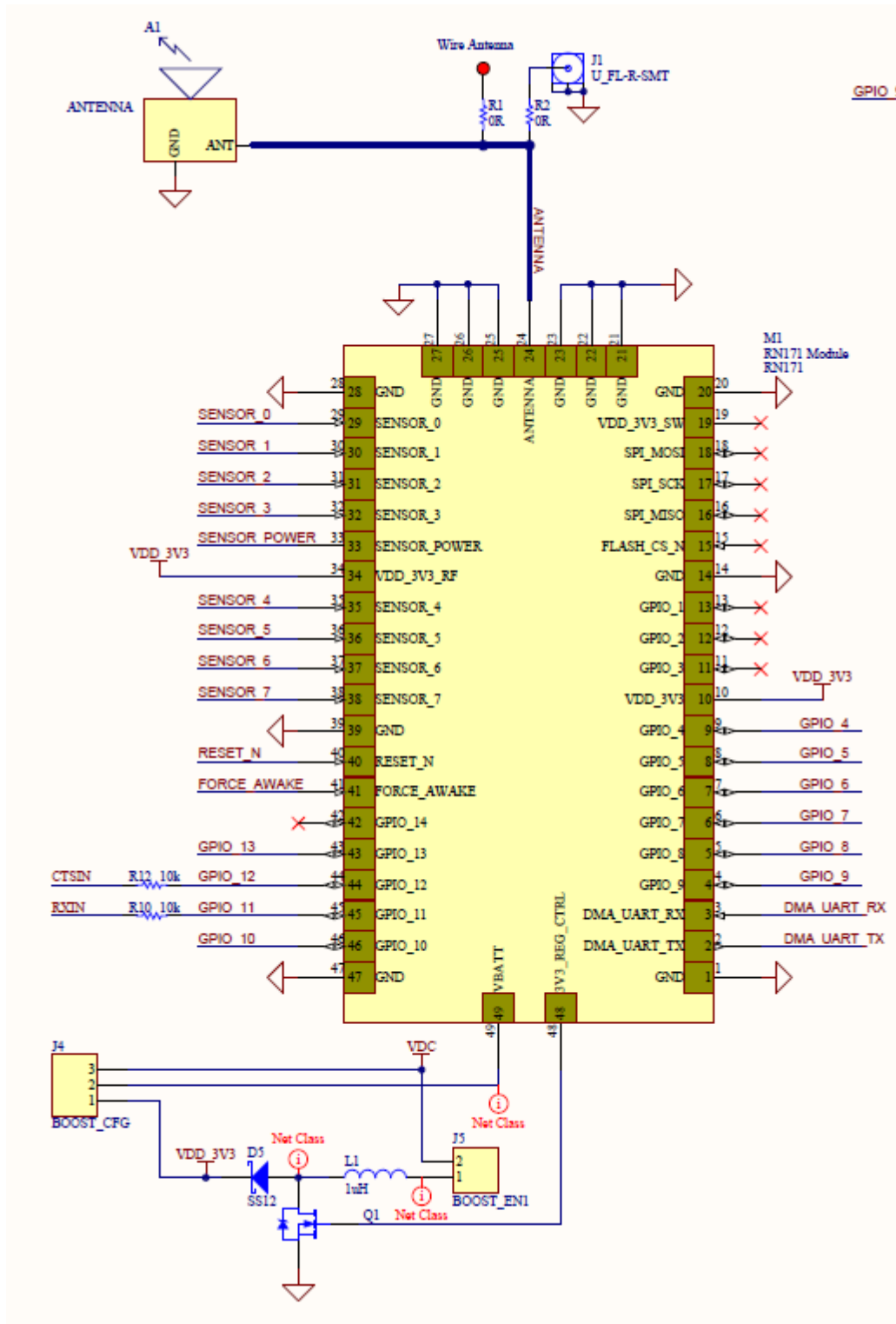

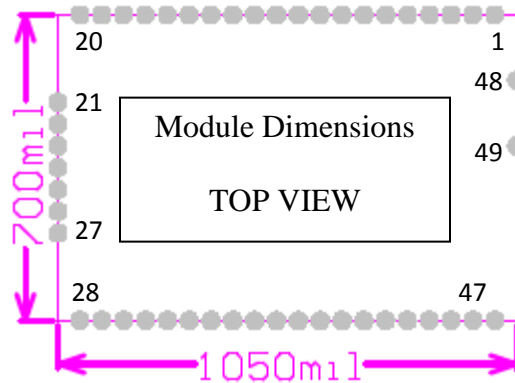
**Pin Description**

Pad Number	Signal Name	Description	Optional Function	Direction
1	GND	Ground		POWER
2	Not Used	Do not connect		No Connect
3	Not Used	Do not connect		No Connect
4	GPIO 9	Enable Adhoc mode, Restore factory defaults, 8mA drive, 3.3V tolerant		IN / OUT
5	GPIO 8	GPIO, 24mA drive, 3.3V tolerant		IN / OUT
6	GPIO 7	GPIO, 24mA drive, 3.3V tolerant		IN / OUT
7	GPIO 6	GPIO, 24mA drive, 3.3V tolerant, Connection STATUS on Roving Firmware		IN / OUT
8	GPIO 5	GPIO, 24mA drive, 3.3V tolerant,		IN / OUT
9	GPIO 4	GPIO, 24mA drive, 3.3V tolerant	Association STATUS	IN / OUT
10	VDD_3.3V	3.3V Power Supply		POWER
11	GPIO 3	GPIO, 8mA drive, 3.3V tolerant		IN / OUT
12	GPIO 2	GPIO, 8mA drive, 3.3V tolerant		IN / OUT
13	GPIO 1	GPIO, 8mA drive, 3.3V tolerant		IN / OUT
14	GND	Ground		GND
15	Not Used	Do not connect		No Connect
16	Not Used	Do not connect		No Connect
17	Not Used	Do not connect		No Connect
18	Not Used	Do not connect		No Connect
19	Not Used	Do not connect		No Connect
20	GND	Ground		GND
21, 22, 23	GND	Ground		GND
24	ANTENNA	802.11b/g antenna		RF
25, 26, 27	GND	Ground		GND
28	GND	Ground		GND
29	SENSOR 0	Sensor Interface, Analog input to module, <b>1.2V tolerant</b>		INPUT
30	SENSOR 1	Sensor Interface, Analog input to module, <b>1.2V tolerant</b>		INPUT
31	SENSOR 2	Sensor Interface, Analog input to module, <b>1.2V tolerant</b>		INPUT
32	SENSOR 3	Sensor Interface, Analog input to module, <b>1.2V tolerant</b>		INPUT
33	SENSOR POWER	Output voltage from module, 3.3V Max		POWER
34	VDD_3.3V_RF	3.3V RF Power Supply (connect to 3.3V rail)		POWER

35	SENSOR 4	Sensor Interface, Analog input to module, <b>1.2V tolerant</b>		INPUT
36	SENSOR 5	Sensor Interface, Analog input to module, <b>1.2V tolerant</b>		INPUT
37	SENSOR 6	Sensor Interface, Analog input to module, <b>1.2V tolerant</b>		INPUT
38	SENSOR 7	Sensor Interface, Analog input to module, <b>1.2V tolerant</b>		INPUT
39	GND	Ground		GND
40	RESET	<b>Optional</b> Module Reset Signal (active low), 100k Pull up, apply pulse of at least 160us, 3.3V Tolerant		INPUT
41	FORCE_AWAKE	<b>Optional</b> Module Awake Signal (active high), 100k pull down, apply pulse of at least 260us, 3.3V Tolerant		INPUT
42	GPIO 14	GPIO, 8mA drive, 3.3V tolerant		IN / OUT
43	UART_RTS	UART RTS flow control, 8mA drive, 3.3V tolerant		OUT
44	UART_CTS	UART CTS flow control, 3.3V tolerant		IN
45	UART_RX	UART RX, 3.3V tolerant		IN
46	UART_TX	UART TX, 8mA drive, 3.3V tolerant		OUT
47	GND	Ground		GND
48	SREG_3V3_CTRL	Boost Regulator Control		OUT
49	VDD-BATT	Battery input, 2.0-3.3V with boost regulator in use, connect to VDD if not using boost regulator		POWER

**NOTE #1:** Any of the sensors 0-3 can be used to wake the module. The sensor pins are 1.2V tolerant. **DO NOT** apply 3.3V on these pins. **DO NOT** apply 3.3V on any of sensor pins.

**NOTE #2:** When sensor pins are used as sensor inputs, they saturate at 400mV. Sensor pins will accept input voltages up to 1.2V but will saturate at 400mV. **DO NOT** apply 3.3V on any of sensor pins.

**Physical Dimensions**

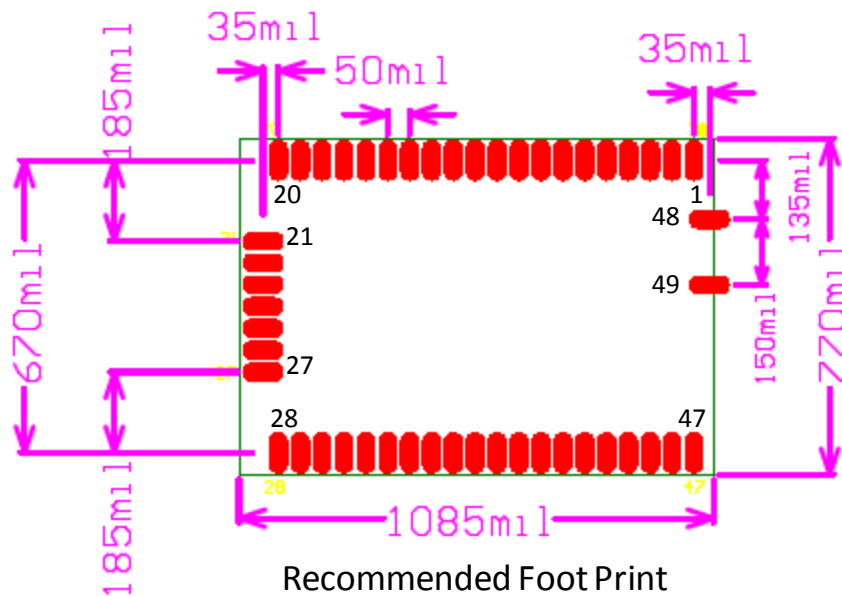

**Recommended Foot Print**

Recommend footprint pad size: 40 mil x 90 mil

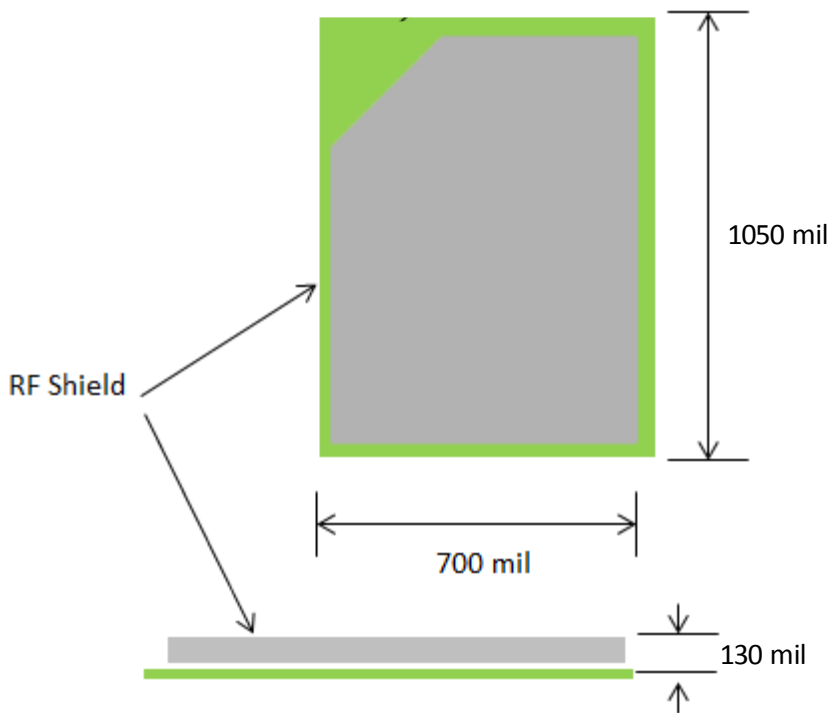

## Design Concerns

### Antenna Design.

**1. PCB Trace Antenna:** A recommended PCB trace Antenna pattern is shown below. The antenna ground should be connected with at least 2 vias to the ground plane and / or ground polygon on both top and bottom layers.

The ground plane should come close to the antenna, exactly where shown in the diagram. The distance is critical. There should be no ground place / trace under the antenna, under any circumstance.

The antenna feed will go through the polygon on a 50 ohm impedance trace to the source of the signal. Unless the antenna trace is exactly 50 ohm and the source has a 50 ohm output impedance a matching PI filter should be used (2 capacitors and an inductor).

The left side of the antenna should be placed on the PCB edge. If not possible please leave at least 1 inch of clearance from any trace or ground plane. The top and bottom of the antenna (the shorter side) should either be placed on the PCB edge or have at least 1 inch clearance from any trace or ground plane.

To control the impedance of the antenna feed the board should be a 4 layer board with a dedicated ground plane and a thickness of around 8-14 mil between the ground plane and the top layer (where the antenna feed is routed). A two layer board would not be thin enough to obtain the desired impedance using a decent width for the trace.

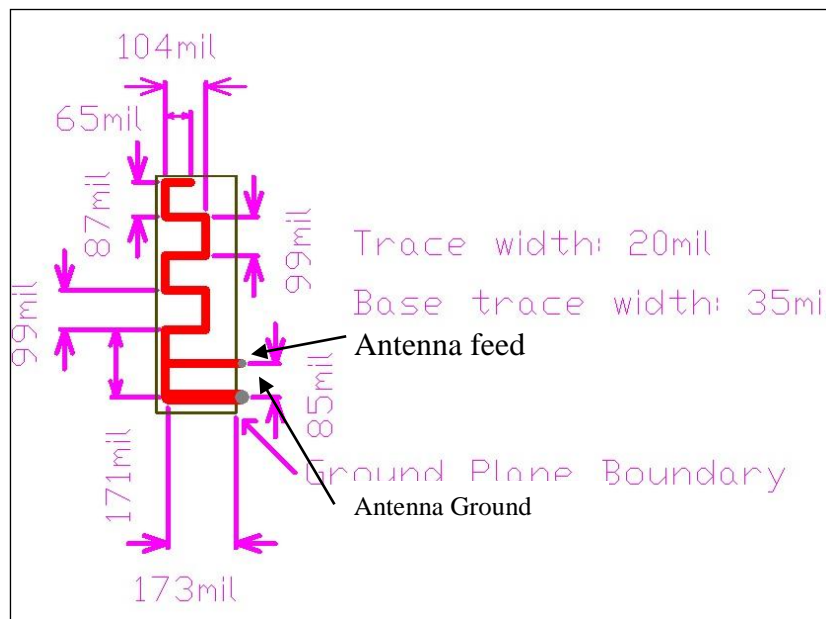

The trace from the RF pad to the antenna feed should be of 12mil thickness on a four layer PCB to achieve 50 ohms impedance matching. This is shown in the diagram below:



12 mil thick trace from RF pad to antenna feed

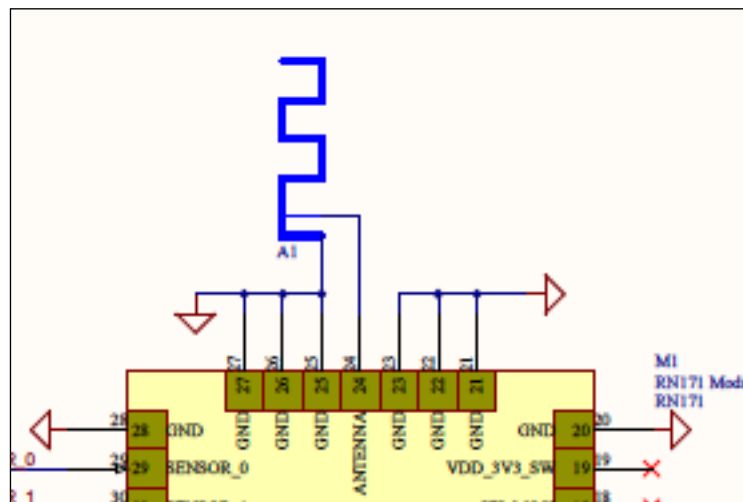
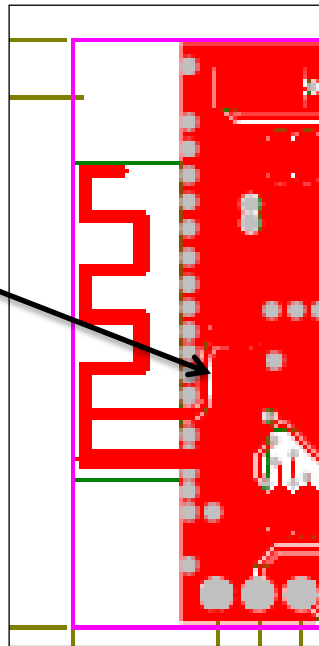

**2. Chip Antenna:** A recommended chip antenna is the FR05-S1-N-0-104 manufactured by Fractus. Please refer to its data sheet and user guide for additional information.

A recommended chip antenna layout is shown below. Impedance matching components are required to match the antenna impedance to 50 ohms. A recommended value is using a 3.3nH inductor and a 1.8pF capacitor as shown in the diagram below.

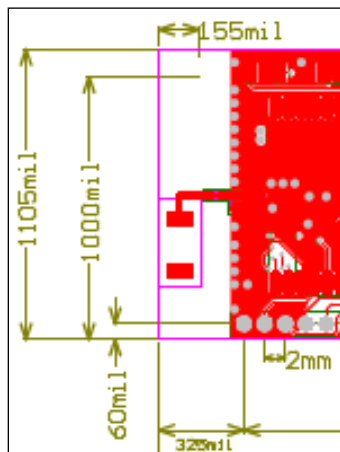
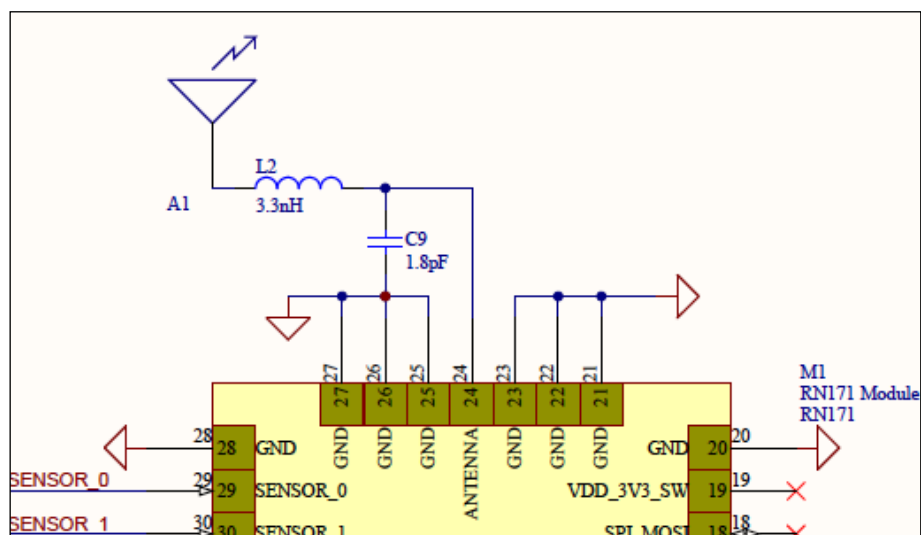
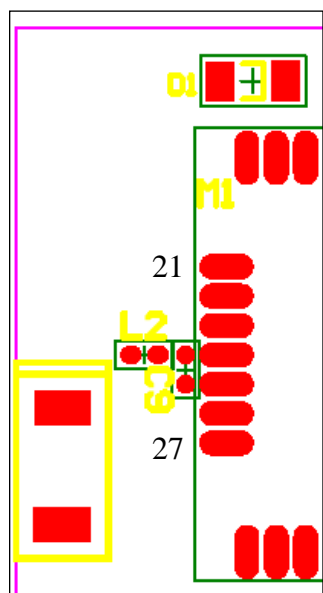

Layer Stack Up Detail for: rn-174.PcbDoc

Layer Name	Gerber Document	Copper Thickness	Dielectric Height	Dielectric Material	Dielectric Type
Top Solder Mask	(.BTS)		0.4mil	Solder Resist	
Top Layer	(.BTL)	1.4mil	8mil	FR-4	PrePrep
Ground Plane	(.BPL)	1.4mil	40mil	FR-4	Core
Mid Layer	(.B1)	1.4mil	8mil	FR-4	PrePrep
Bottom Layer	(.BBL)	1.4mil	8mil	FR-4	PrePrep
Bottom Solder Mask	(.BBS)		0.4mil	Solder Resist	

**3. Wire Antenna:** To implement a wire antenna, drill hole through the board on the RF pad (pin 24) to place the wire antenna. To provide an impedance match of 50 ohms, the RF path from the RF pad (Pin 24) to the location of the wire antenna should be of 12 mil thickness on a four layers PCB. Please refer to the diagram below. It is recommended to use a 18 gauge wire on length 1 inch  $\pm$  0.25 inch. For best performance, the wire antenna should be perpendicular to the ground plane.

**NOTE:** There should be no thermal relief connectors on GND for RF path and on the Ground plane.

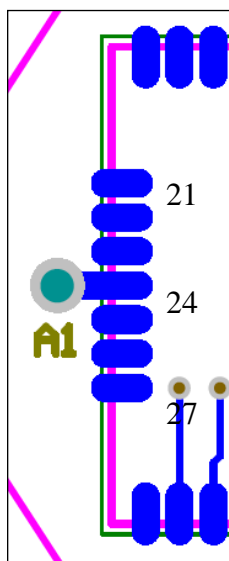

Layer Stack Up Detail for: rn-174.PcbDoc

Layer Name	Gerber Document	Copper Thickness	Dielectric Height	Dielectric Material	Dielectric Type
Top Solder Mask	<.GTS>		0.4mil	Solder Resist	
Top Layer	<.GTL>	1.4mil	8mil	FR-4	PrePreg
Ground Plane	<.GPI>	1.4mil	42mil	FR-4	Core
Mid Layer	<.GI>	1.4mil	8mil	FR-4	PrePreg
Bottom Layer	<.GBL>	1.4mil			
Bottom Solder Mask	<.GBS>		0.4mil	Solder Resist	

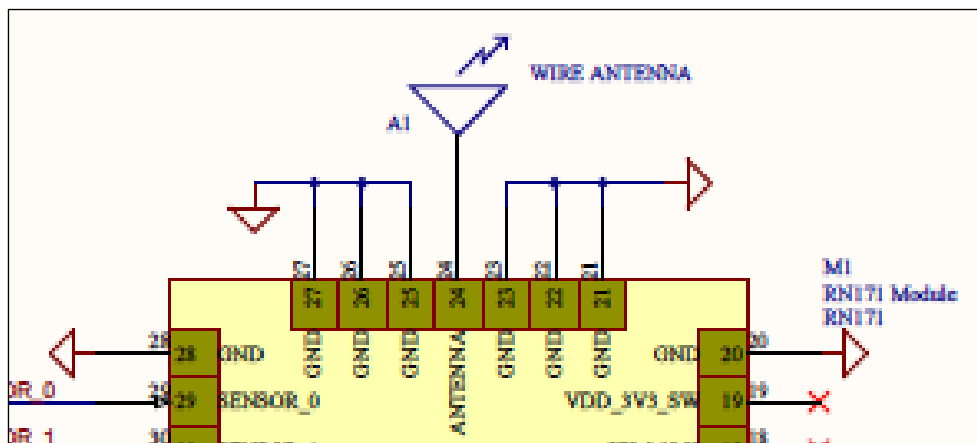

## 4. U.FL. connector

An example to implement an U.FL. connector is shown below. The trace from the RF pad to the U.FL connector should be of 12 mil thickness to achieve 50 ohm impedance matching on a four layer board.

The part number of the U.FL. connector used for certification of the module is U.FL-R-SM from Hirose.

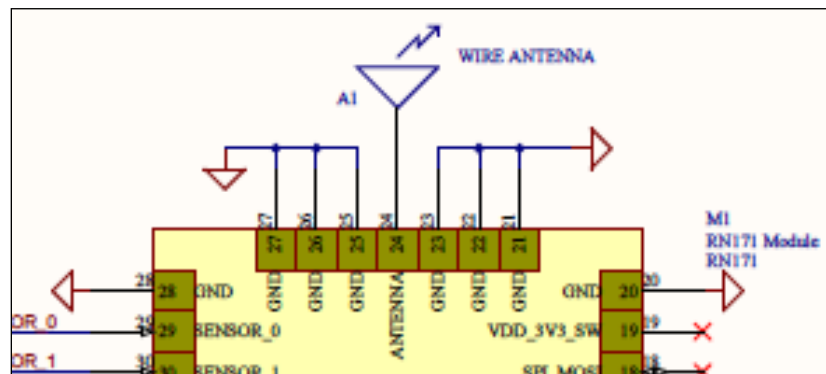
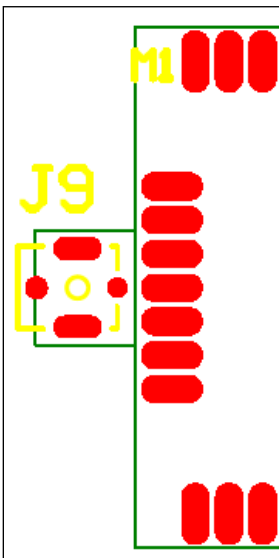

Layer Stack Up Detail for: rn-174.PcbDoc

Layer Name	Gerber Document	Copper Thickness	Dielectric Height	Dielectric Material	Dielectric Type
Top Solder Mask	<.GTS>		0.4mil	Solder Resist	
Top Layer	<.GTL>	1.4mil	8mil	FR-4	PrePreg
Ground Plane	<.GPI>	1.4mil	42mil	FR-4	Core
Mid Layer	<.GI>	1.4mil	8mil	FR-4	PrePreg
Bottom Layer	<.GBL>	1.4mil			
Bottom Solder Mask	<.GBS>		0.4mil	Solder Resist	

**Using Batteries** The RN-171 module does not have a Boost Regulator circuit. This makes the choice of batteries absolutely critical because if the battery voltage drops below 3V, the module performance will start to degrade.. One possible battery of choice is the ER14505 3.6V battery. This battery is known to have a long battery life. If this battery is used to power the module, it is recommended that you use a 1000uF to 3000uF bypass capacitor as the ER14505 battery has high output impedance.

**Boost Regulator:** The RN-171 does not have a boost regulator on board. A recommended circuit for the boost regulator is shown below.

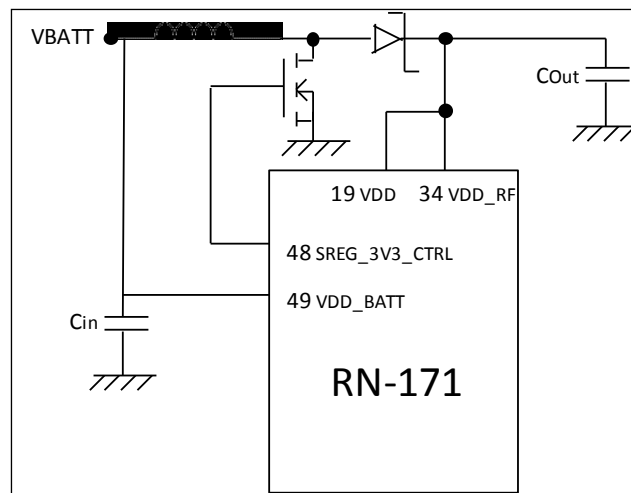

Designs that include the boost regulator will provide good supply to the flash even when the battery voltage drops close to 1.8V.

If a board containing RN-171 does not include the boost regulator, it **SHOULD** include a 2.7V undervoltage reset circuit to prevent the module from accessing flash when supply voltage falls below 2.7V. All supported flash chips are rated for minimum VDD of 2.7V.

Recommended values of the parts for the Boost Regulator circuit are:

Designator	Description	Value	Manufacturer	Manufacturer PN	Vendor	Vendor PN
D	Diode Schottky 1A 20V SMA	SS12	Micro Commercial Co	SS12-TP	DigiKey	SS12-TPCT-ND
L	Inductor 1.0uH 30% SMD	1uH	Taiyo Yuden	NR3015T1R0N	DigiKey	587-1647-1-ND
Q	MOSFET N-CH 20V 5.9 A	DMN2050L	Diodes Inc.	DMN2050L-7	DigiKey	DMN2050LDICT-ND

It is recommended to use a low voltage detector circuit such as XC61 from Torex tied to the RESET pin of the RN-171 module to protect from low voltage.

**Powering from a 3.3V Regulated Source:** Apply 3.3V regulated power to pins 10, 34 and 49. Leave pin 48 (SREG\_3V3\_CTRL) unconnected. **Do not connect pin 48 to ground. leave it as unconnected.**

**Solder Reflow.** Reflow temperature must not exceed 220C.

To reflow solder the RN-171 module onto a PCB Roving recommends a RoHS compliant solder paste equivalent to the NIHON ALMIT paste or OMNIX OM-310 solder paste from Alpha metals.

**NOTE: Use no clean Flux, Do NOT water wash!**

Note also, that the temperature profile is based on the IC level and other components level only (without the shield can). So if we go on module perspective, above 245C profile should be acceptable.

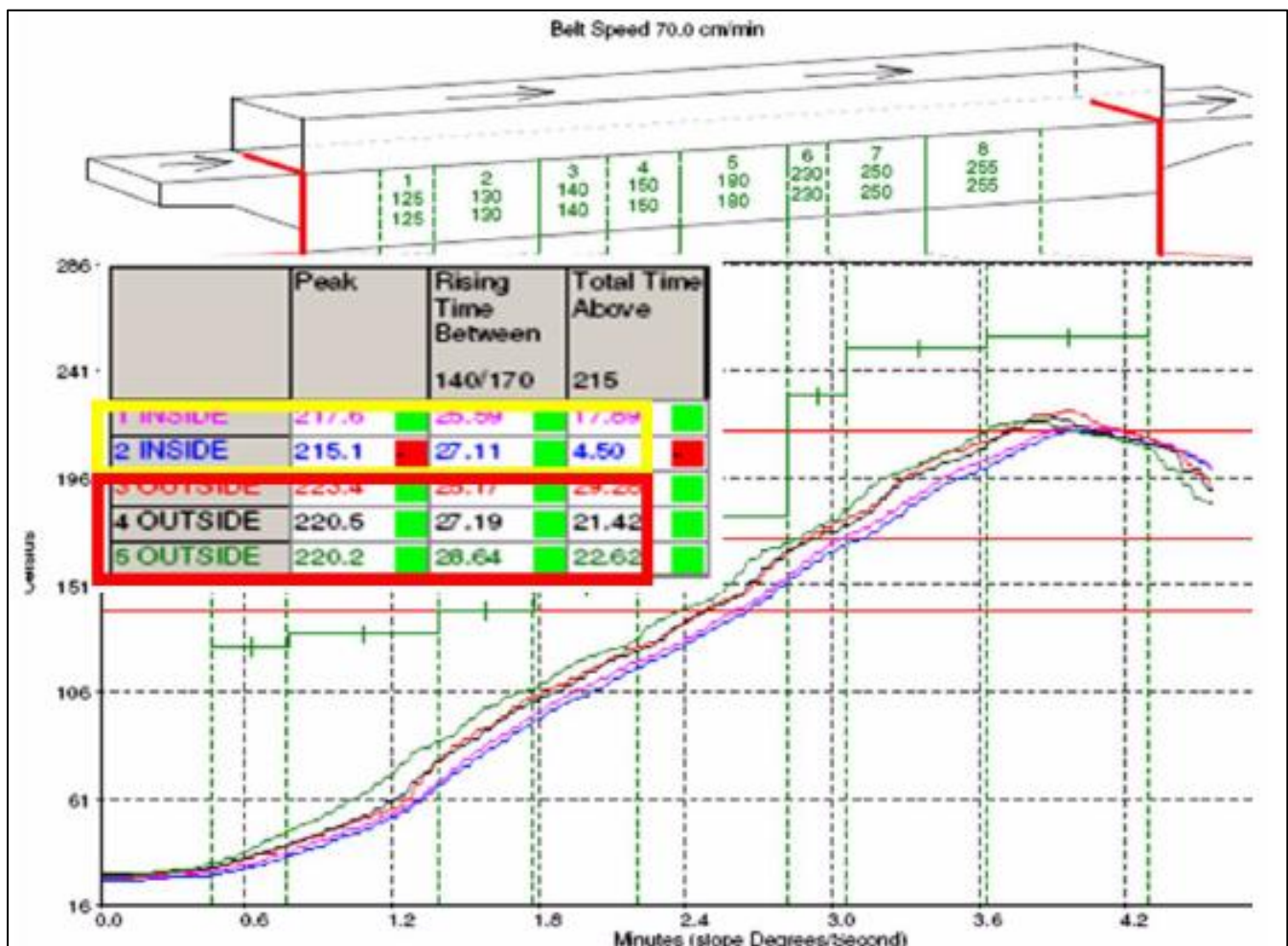

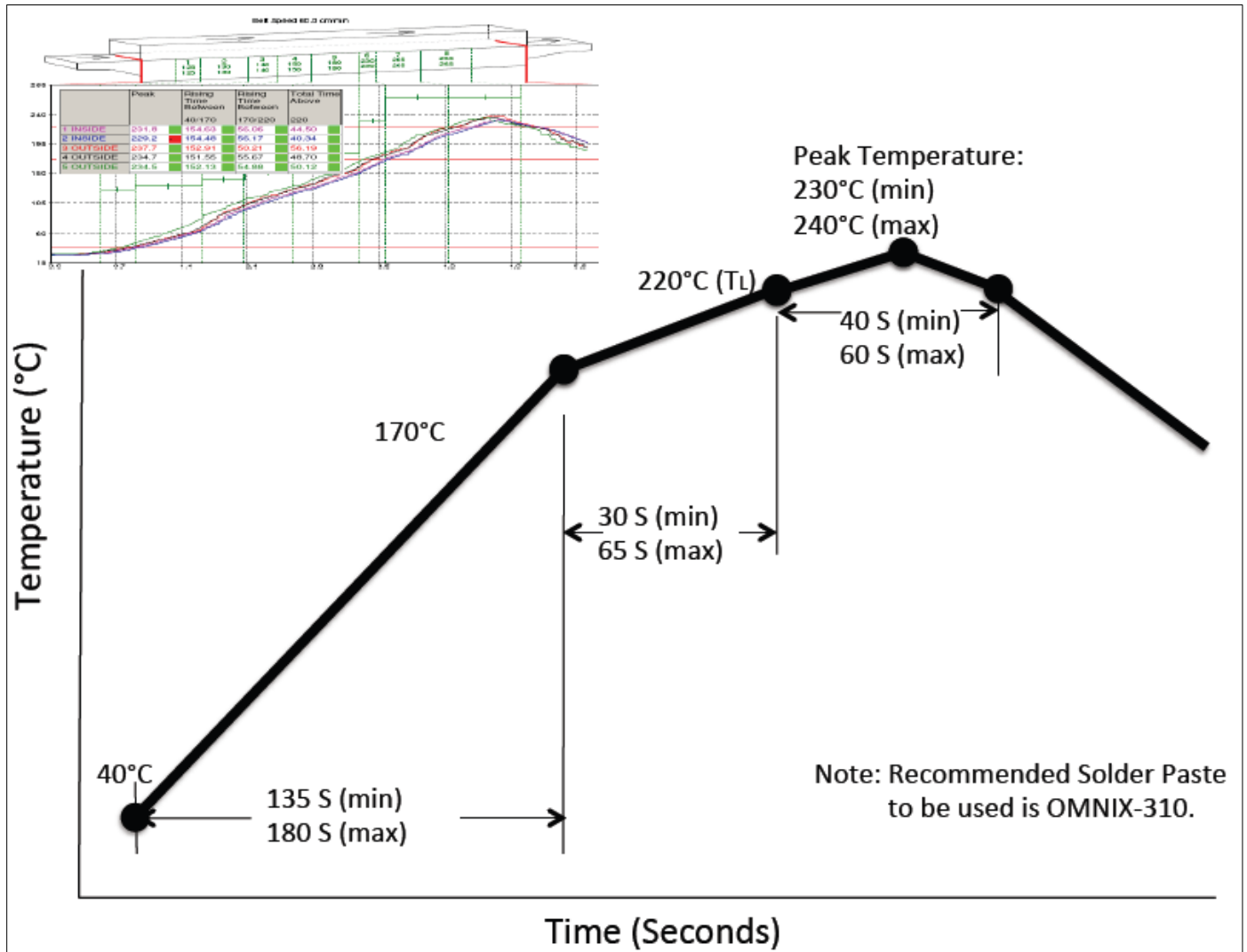

**Ordering Information**

Part Number	Description
RN-171	Industrial Temperature (- 40 to + 85 C) with RF pad for external antenna
RN-174	Development board for RN-171 module containing RS-232 and TTL UART hardware interface, status LEDs, power regulator, sensor connections
RN-SMA4-RP	4" external antenna with reverse polarity SMA connector. Used with RN-UFL-SMA6
RN-UFL-SMA6	6 inch cable with U.FL connector on one end and SMA on the other
For other configurations, contact Roving Networks directly.	

Visit <http://www.rovingnetworks.com> for current pricing and a list of distributors carrying our products.

**Copyright © 2010 Roving Networks. All rights reserved.**

Roving Networks reserves the right to make corrections, modifications, and other changes to its products, documentation and services at any time. Customers should obtain the latest relevant information before placing orders and should verify that such information is current and complete.

Roving Networks assumes no liability for applications assistance or customer product design. Customers are responsible for their products and applications using Roving Networks components. To minimize the risks associated with customer products and applications, customers should provide adequate design and operating safeguards.

Roving Networks products are not authorized for use in safety-critical applications (such as life support) where a failure of the Roving Networks product would reasonably be expected to cause severe personal injury or death, unless officers of the parties have executed an agreement specifically governing such use.

All other trademarks are property of their respective owners.